

Operating Instructions

3644CG



Work Surface 36" x 44" 3/16" CNC cut steel ~ Aluminum Industrial BI Fan
2600 CFM@2" ~ 1- 24"x24"x4" Merv 8 Box Filter 1- 24"x24"x4" Merv 13 Box
Filter
1- 24"x24"x2" Steel Mesh Spark Filter

DENRAY MACHINE	
(800) 766-8263	
MODEL NUMBER	3644CG
SERIAL NUMBER	475634
MOTOR HP 2.0	AMP 17.6/8.8
VOLTAGE	120 220 1 PH /60Hz
FAN TYPE	16.5" LC
MFG DATE	11/4/19
FILTER NUMBER	1- 24x24x2 Spark Filter
1- 24x24x4 Merv 8	2-18x24x6 HEPA
1- 24x24x4 Merv 13	Filters
SWITCH TYPE	EOT16U3P3-S

To find YOUR tables pertinent information please locate the table sticker on your table.

*Please note the image above is a "generic" table sticker for visual purposes only! The table sticker on your machine reflects how it left the manufacturer and does not reflect any after-market changes made by previous owners. If you have questions please call Denray Machine at (800) 766-8263.

WARRANTY

This Machine is covered with a 12 month warranty. The warranty covers replacement parts, except filters. The only way Denray will cover the labor is the work must be done by Denray at Denray's Facility. The shipping must be provided by the customer (owner of the machine) both ways. You may contact the dealer you purchased the machine from, and discuss with them, the possibility of their assistance in helping to solve the problem in your facility. Denray assumes or accepts no responsibility more than the cost of the machine. In the case of repair Denray will determine either to fix or replace the product. Denray reserves the right to modify or change the design of this and any model of their machines, without changing or updating any previous manufactured machine. The warranty will not cover any damage done by fire or any other act of nature or if abuse or improper maintenance was or was not performed.

Filter Compartment

PLEASE NOTE THAT AS OF 2019 DENRAY'S GRIND MODELS ARE NO LONGER PAINTED GREEN AND ARE NOW PAINTED OUR STANDARD DENRAY BLUE

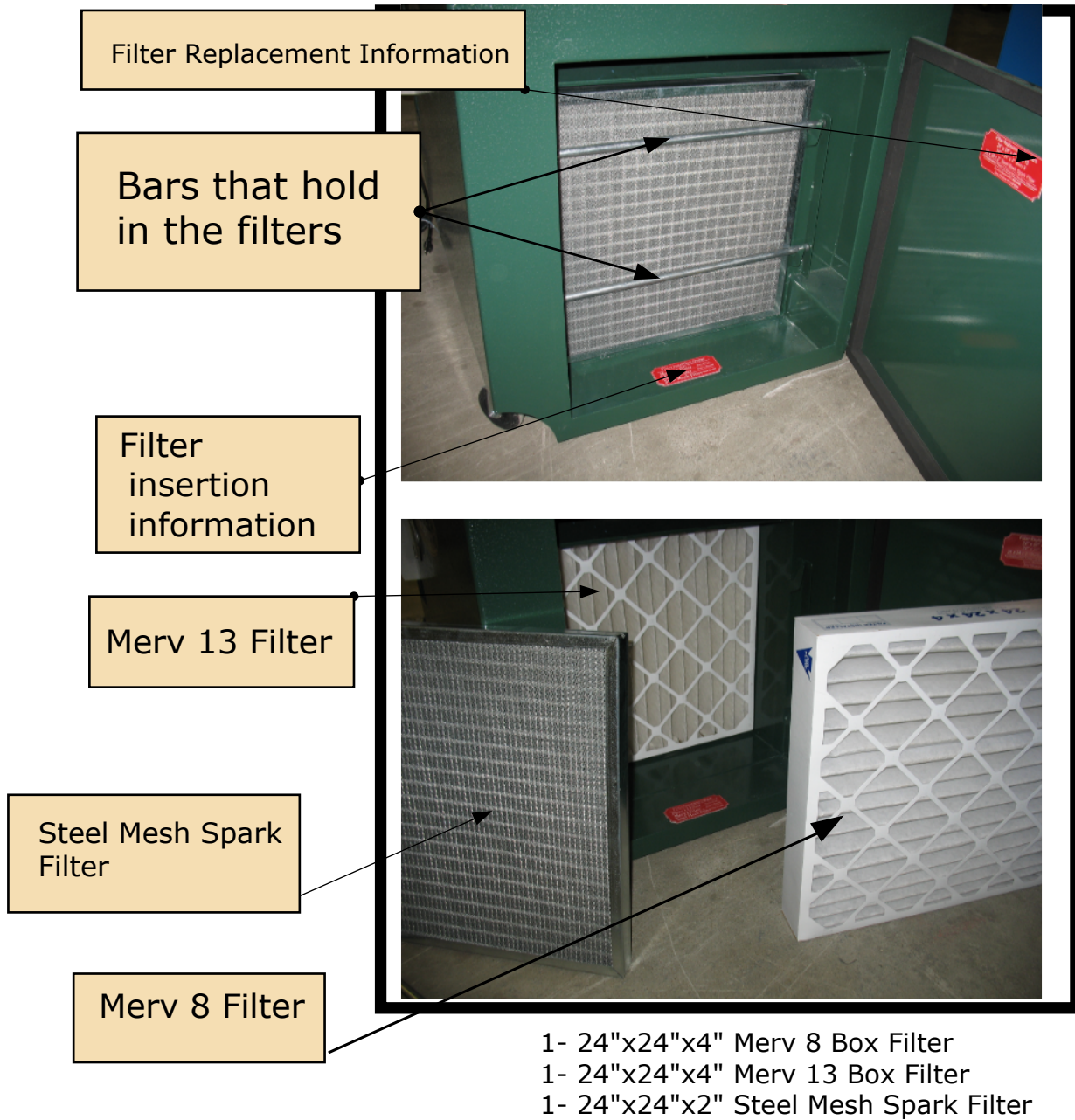

The Merv 8 filter is the MIDDLE filter and it will capture the bulk of the dust particulates. Most of what goes through it will get captured in the back or third filter. The spark filter is designed to HELP PREVENT sparks from getting to the filters behind it. It is not an absolute spark STOPPER. The filter change out will have to be determined in each different dust exposure application. A general Rule is to replace the Merv 8 or middle filter 2-3 times before the need to replace the Merv 13 or last filter. When the Magnehelic gauge reaches near the red line on the gauge that will be good a indicator the third or last filter will need to be replaced. The spark filter will need to be cleaned daily if sparks are created on the work surface. The glue and paper particles from the abrasives are flammable, the filter will not burn, but even metal dust will burn in state of powder form. Remove and clean with compressed air or wash and either let dry completely or blow all moisture with compressed air.

Never Allow Any Unauthorized or Untrained Person To Operate This Machine

Lockout and tagout any time maintenance is performed on this machine

WARNING
NEVER GRIND OR SAND ANY ALUMINUM OR MAGNESIUM PRODUCT ON THIS MACHINE

Filters are the main need of maintenance, the cleaner the filters are kept the better the machine will perform. These filters are to be replaced, The steel mesh filter is cleanable, It can be blown out with compressed air, in either a booth type setting, or in a well ventilated area. May also be washed out with WATER only.

FILTER REPLACEMENT NUMBERS

The filters for this machine is based off filter description not a certain filter number.

24" x 24" x 4" Merv 8

24" x 24" X 4" Merv 13

24" x 24" x 2" steel mesh spark filter

The filters will clean better with machine off, you may shut machine off and before it slows down to a complete stop, pulse the filter and allow the fan to prevent the dust from exiting the filter compartment.

Filter replacement number is on the inside of the filter door. Be sure to replace with same type of filter or a filter made of polyester media.

The exhaust air will exit through opening to the floor, if muffler is added the plate on the end will be located here to force the air through the muffler

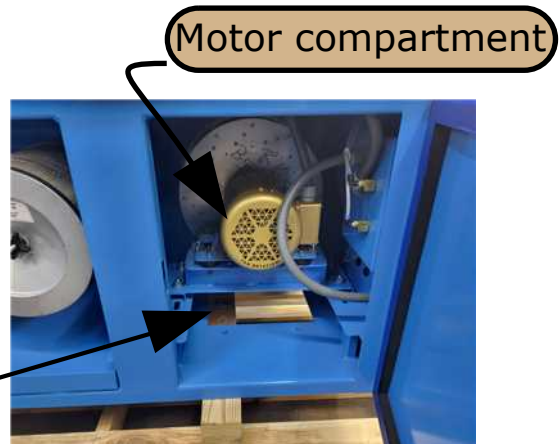

115/220 Volt 1 phase

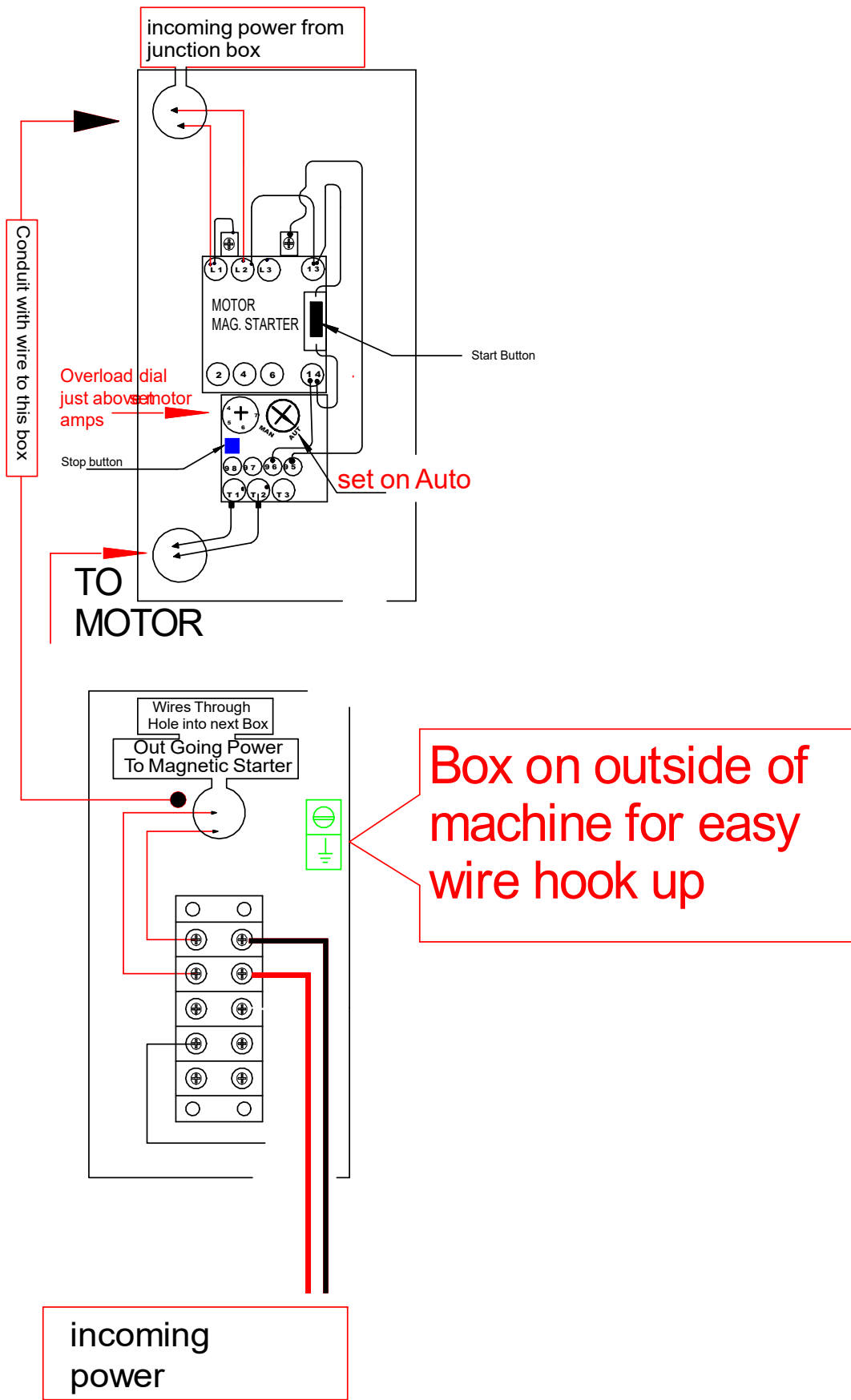

230 Volt 3 phase

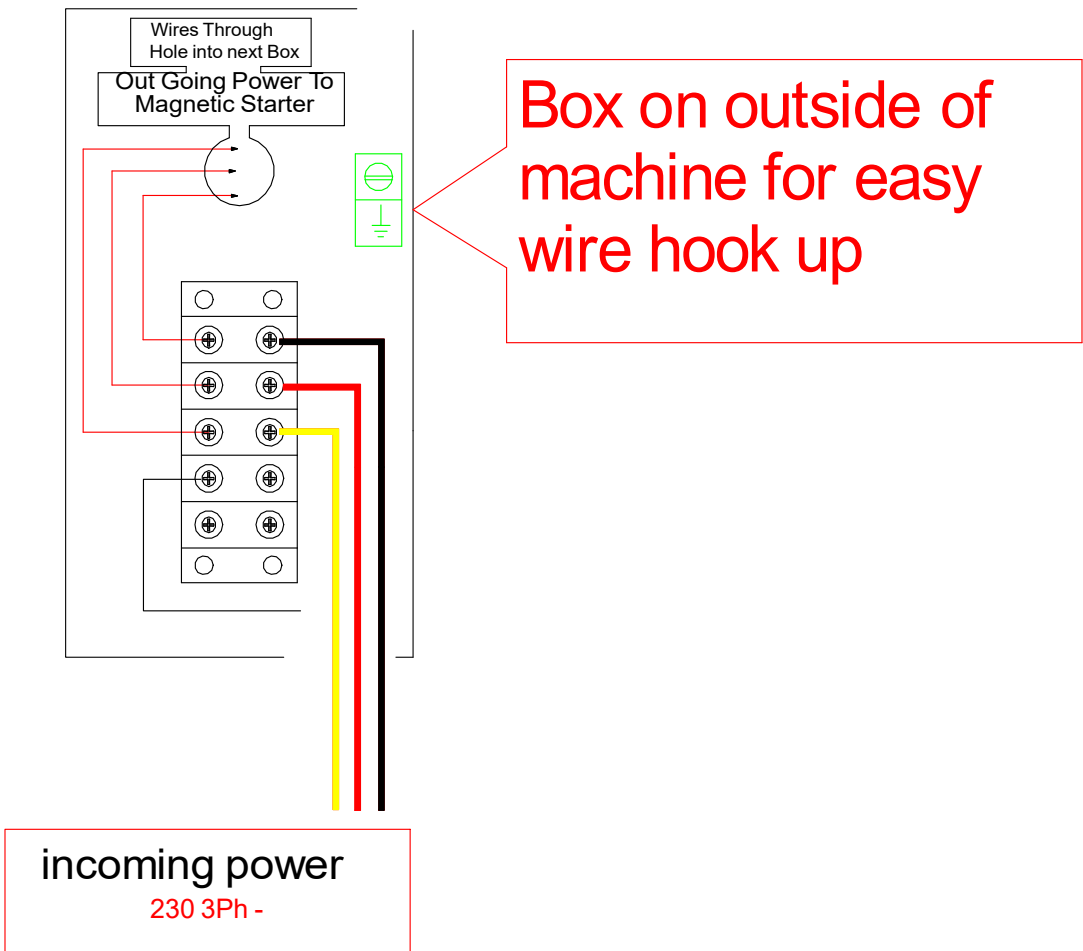
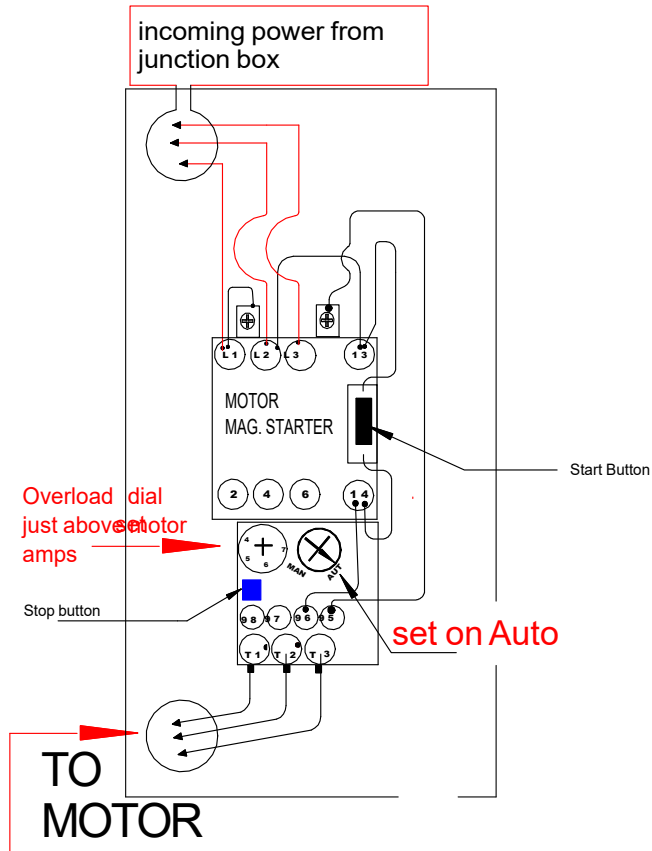

460 Volt 3 phase

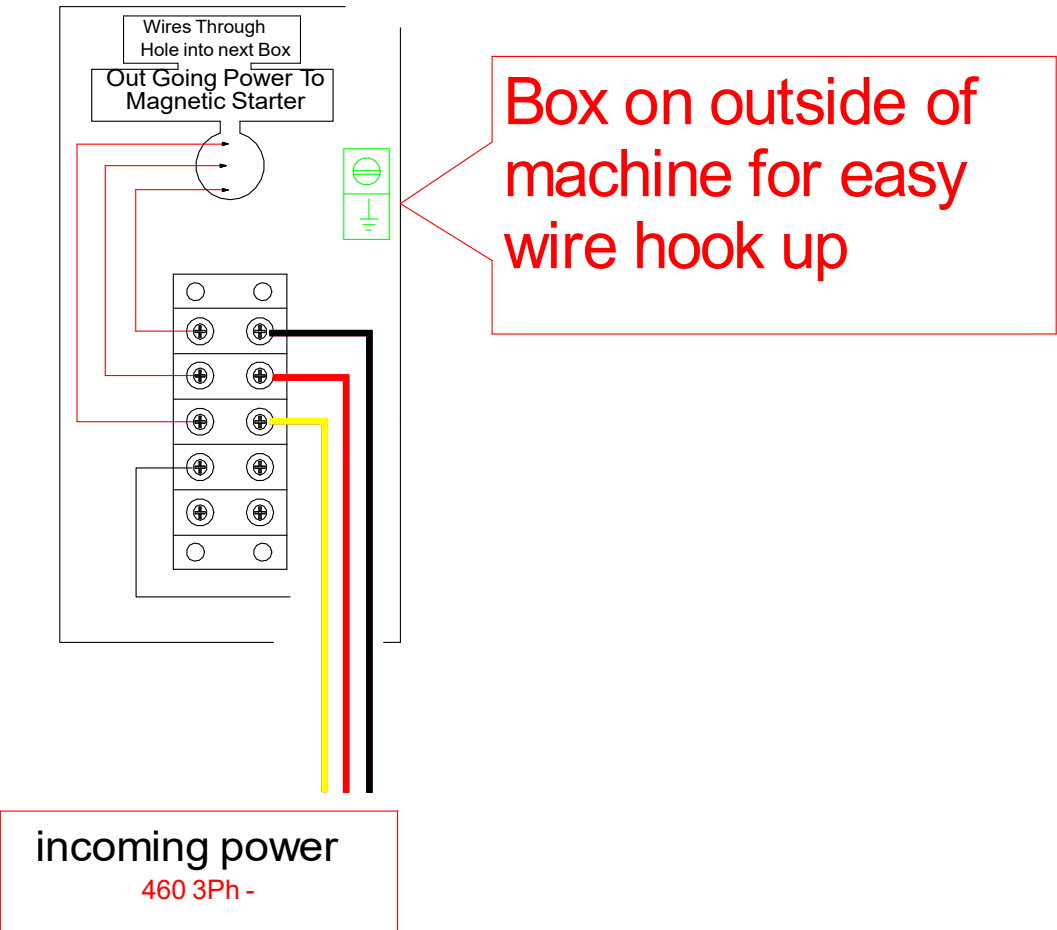
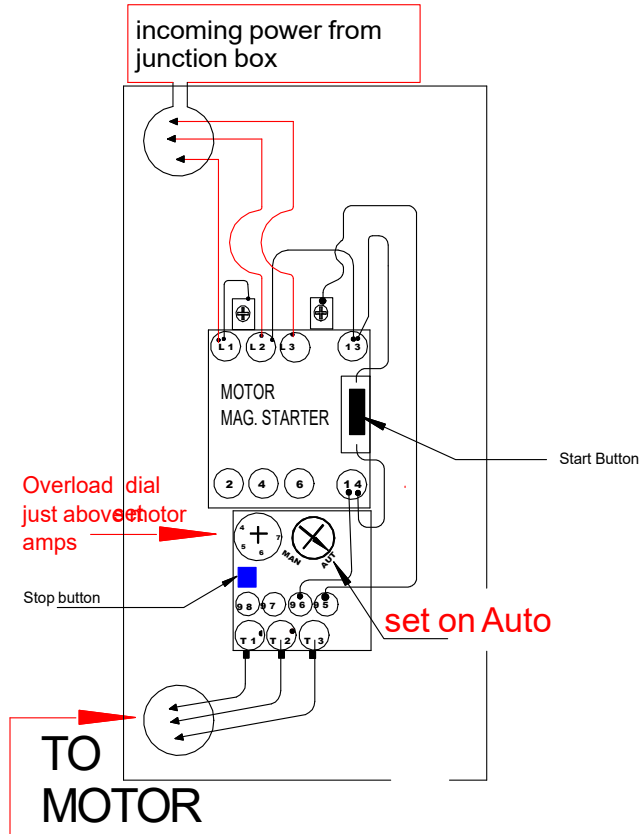

CHECK FAN ROTATION

WARNING DISCONNECT ALL POWER BEFORE SERVICING

TO CHECK THE MOTOR ROTATION. OPEN MOTOR DOOR AND SEE IF THE FAN IS ROTATING THE SAME DIRECTION AS THE ARROW ON THE BACK OF THE MOTOR. IF IT IS GOING THE OPPOSITE DIRECTION OF THE ARROW SWITCH L1 AND L2 ON THE TERMINAL BLOCK

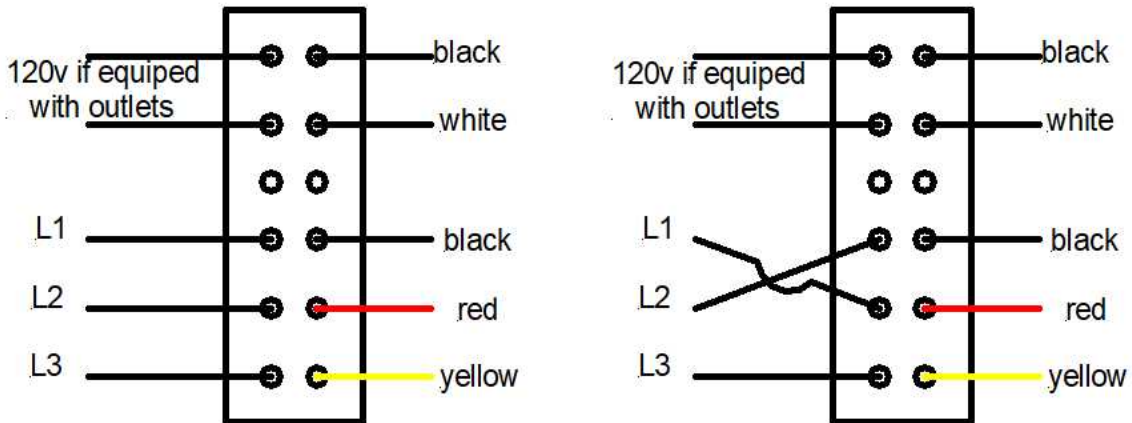

When the fan is going the wrong direction you can loose up to 50% of the suction.

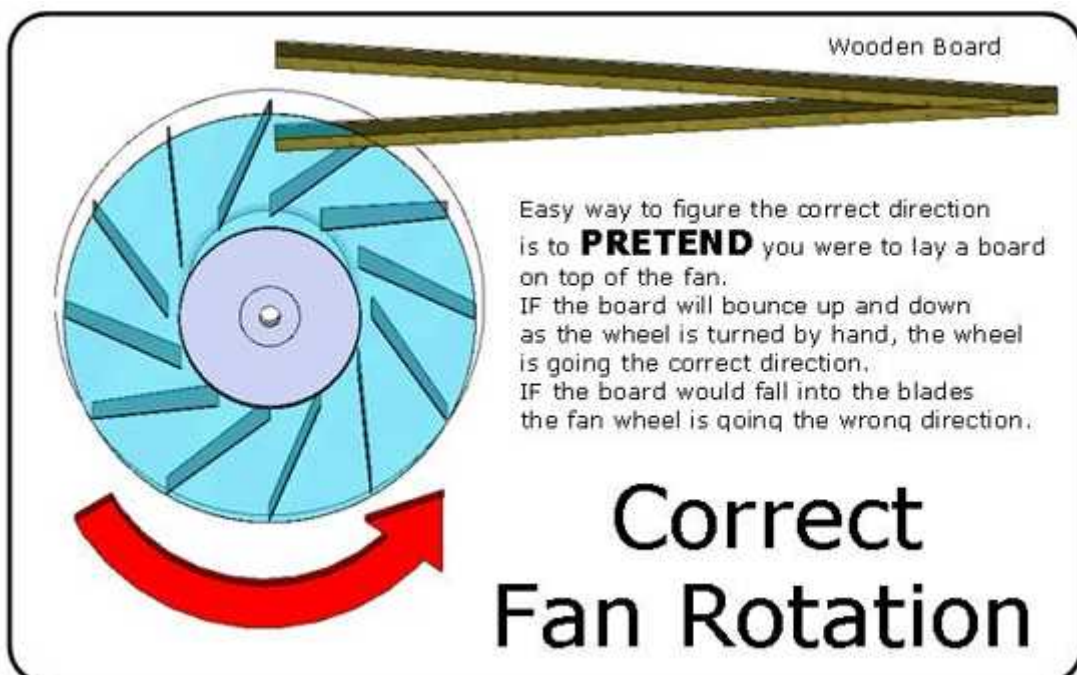

IF FAN IS ROTATING BACKWARDS

WARNING DISCONNECT ALL POWER BEFORE SERVICING

TO CHECK THE MOTOR ROTATION. OPEN MOTOR DOOR AND SEE IF THE FAN IS ROTATING THE SAME DIRECTION AS THE ARROW ON THE BACK OF THE MOTOR. IF IT IS GOING THE OPPOSITE DIRECTION OF THE ARROW SWITCH L1 AND L2 ON THE TERMINAL BLOCK

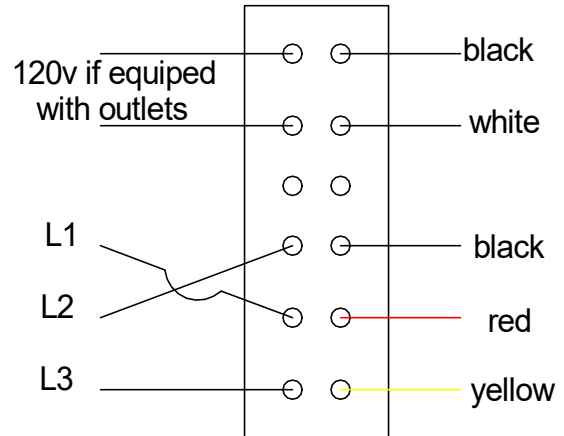
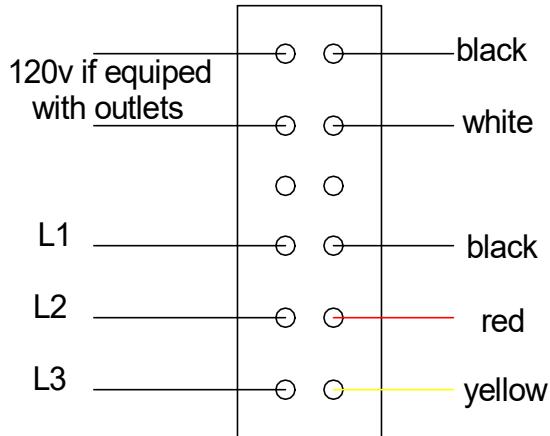

TROUBLE SHOOTING

All the below solutions are meant to be done only by a qualified technician

1	Motor not running	Look to see if L1- L2 -L3 wires are in and secured and proper voltage is there	Check if wires at bottom of mag starter to the motor are in bottom and secured.
2	The above checks OK	In center of the contactor is a rectangle post that is hooked to coil below. With screwdriver push in and see if motor will run. If motor will run something is wrong with the push buttons, That activates the starter.	
3	Motor runs when center post is held in, but not by the switches	Make sure every wire is secured on starter if still no results call Denray for further assistance	
4	If center post is held in and nothing happens hook power leads to motor leads at bottom of mag starter if motor runs the problem is the starter.	Call factory for switch replacement	
5	If on switch closes mag starter and motor does not run.	FIRST take tester and check see if there is the proper voltage at bottom of starter	
6	If proper voltage is at bottom of starter	Check to see wiring at motor is properly hooked together	
7	Mag starter works and motor only hums	Check for proper voltage check all wire connections to be tight check wiring diagram and motor leads to be correct	
8	Motor runs for a few minutes and shuts off	Turn the amp dial on overload to increase the number. Increase only 1 amp at a time Never increase more than 2 amps above motor full load amps	
9	Filter Cleaning valve will not pulse	Check the three 1 amp fuses on top of the transformer in the switch box.	
10	Fuses OK	Check wiring in front of and behind the fuses	
11	Fuses and wiring checks out OK	With it being quiet activate the switch and listen to hear a clicking sound from the valve or valves.	
12	You hear it clicking	Make sure air is hooked up to tank	
13	Air is hooked up and it still clicks	Call Denray Replace valve	

TROUBLE SHOOTING

All the below solutions are meant to be done only by a qualified technician

14	Machines with timers Timer not working	Check fuses:: Check wiring between mag starter and timer. Any loose connection, secure the connection
15	Green light on timer does not work	See above Bad timer needs replacement
16	Filters need to be cleaned more often	Turn dial on timer to a lesser number set at factory at approx. every 20 minutes.
17	Lots of dirt remaining on filters after being cleaned	Decrease time between cleanings. Check air pressure going into machine. Keep between 100-140 psi
18	Filter never completely cleans all dirt off	Not supposed to:: Machine designed to operate at 30% filter blockage. The cleaner a filter is the better the machine will perform.
19	Loss of suction on top of table	Dirty filters :: Refer to above
20	Excessive exhaust air on the floor	Any air that is sucked into the table top must come out in exhaust somewhere. Look into adding Muffler to machine
21	Dirt packed in top 1/3 of filters	Rotate filters two times a week 1/4 turn
22	Inside of filters are rusty colored	Blowing water from air tank inside of filter. Drain air tank more often (daily if possible) Installation of a dryer or water trap may be necessary
23	Filters will not come clean	Pull filters out of machine and take blow gun and from inside blowing out give filters a deep cleaning
24	How often do I need to do the above	Some companies do it daily and some weekly and some monthly. You must determine that for yourself
25	Moisture blowed in filters will make filters harder to clean	Refer to 22
26	Are filters washable?	Spun-bond filters in the grind tables can be washed only a couple times and must let thoroughly dry. Filter cleaning service companies may be available in your area.

TROUBLE SHOOTING

All the below solutions are meant to be done only by a qualified technician

27	Fan making a loud roar	Fan rotation backwards, on three phase, switch wires on L1 and L2
28	Lack of proper suction	Fan running backwards will produce 2/3rds less suction check fan rotation Verify Correct Fan Direction on your Machine
29	Machine vibration on direct drive systems	All fans are factory balanced from fan company, fans checked and rebalanced at table MFG, if table has vibration, fan weights may need to be moved to another blade.