

OPERATING INSTRUCTIONS

Mini Booth



DENRAY Machine	
(800) 766-8263	<i>Mini Booth</i>
MODEL NUMBER:	4872MB
SERIAL NUMBER:	476206
MOTOR HP: 5	AMP: 13.4/6.7
MOTOR TYPE:	EM3615T
VOLTAGE:	230/460 /60Hz
FAN TYPE:	20" Comfri
MFG DATE:	06/28/2023
FILTER NUMBER:	EO6060
SWITCH TYPE:	Draf16-14U
Overload	TF42-7.6

To find YOUR tables pertinent information please locate the table sticker on your table.

*Please note the image above is a "generic" table sticker for visual purposes only! The table sticker on your machine reflects how it left the manufacturer and does not reflect any after-market changes made by previous owners. If you have questions please call Denray Machine at (800) 766-8263.

WARRANTY

This Machine is covered with a 12 month warranty. The warranty covers replacement parts, except filters and wooden top (if applicable). The only way Denray will cover the labor is the work must be done by Denray at Denray's Facility. The shipping must be provided by the customer (owner of the machine) both ways. You may contact the dealer you purchased the machine from, and discuss with them, the possibility of their assistance in helping to solve the problem in your facility. Denray assumes or accepts no responsibility more than the cost of the machine. In the case of repair Denray will determine either to fix or replace the product. Denray reserves the right to modify or change the design of this and any model of their machines, without changing or updating any previous manufactured machine. The warranty will not cover any damage done by fire or any other act of nature or if abuse or improper maintenance was or was not performed.

Never Allow Any Unauthorized or Untrained Person To Operate This Machine

Lockout and tagout any time maintenance is performed on this machine

WARNING

NEVER GRIND OR SAND ANY ALUMINUM OR MAGNESIUM, OR ANY SPARK CREATING PRODUCT ON THIS MACHINE

Filters are the main need of maintenance, the cleaner the filters are kept the better the machine will perform. This machine is equipped with timers to clean the filters, every so many minutes a pulse of air will be released into one of the filters, and a few minutes later the other filter will be pulsed, the time is needed to refill the tank. The time between pulses are adjustable, refer to the electrical diagram. Warning if the time is reduced between pulses the filter may plug up reducing the machines performance. The filters can also be pulsed with the machine off, it may blow dust back into the work area, so caution should be used here, pulse the machine then turn machine on to pull dust back into the filters.



The filters will clean better with machine off, you may shut machine off and before it slows down to a complete stop, pulse the filter and allow the fan to prevent the dust from exiting the filter compartment.
Filter replacement number is on the inside of the filter door. Be sure to replace with same type of filter or a filter made of polyester media.

Cartridge Filters 99.95% efficiency down to .5 micron

Filter replacement number Is on inside of this door. MUST replace with the proper fire retardant filter

Dust Drawer Clean regularly, as needed

UMHW Plastic strips for ease of sliding the filters. Must be in place

Bolt that holds the band that secures the filter to the steel plate that slides in the filter unit. This makes removing filters from the plate very easy, Allowing filter deep cleaning a much easier task, thus allowing the filters to be cleaned better and easier.



Never Open Any Door While Machine Is Running

This bolt holds the levers that raise and lowers the filters. Once the machine is in place, remove the nut from this bolt, once the bolt is in the hole pull down on the levers to lock the bolt in place. looks like the picture

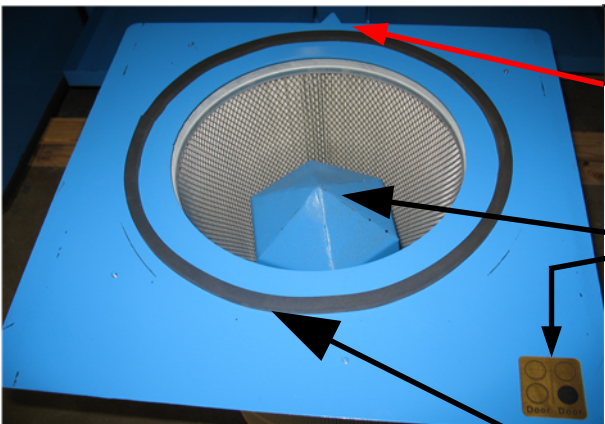
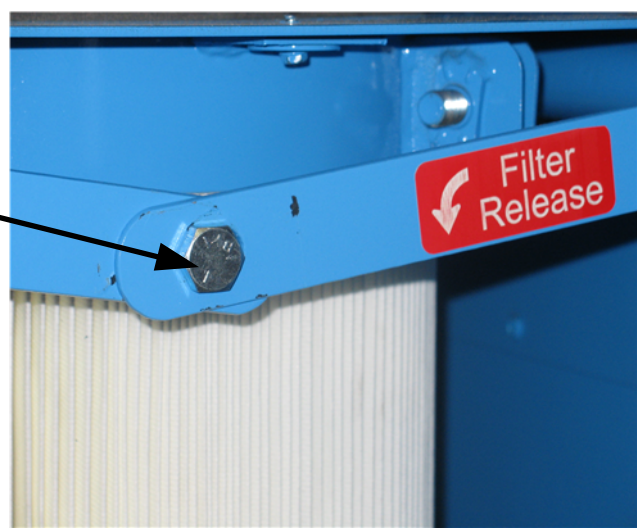

This Vee will align into the filter placed in first

The cone on the inside of the filters enhances the cleaning process. It is bolted into the bottom of the filter.

This shows the location of the four filters, the black circle shows this filter is the front right filter.

This seal needs to be inspected everytime the steel plate is removed. Look to see if any missing rubber, This seal prevents the dust from by passing the filter. If this seal is not intact it needs to be replaced. Order a booth filter plate seal

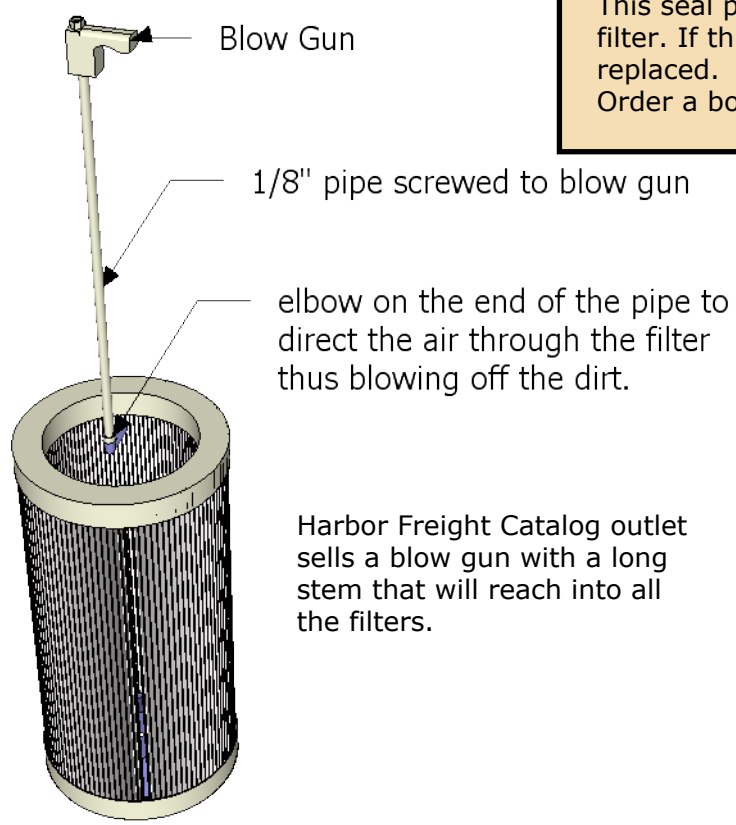

Harbor Freight Catalog outlet sells a blow gun with a long stem that will reach into all the filters.

Filter Cleaning is almost the only thing that has to be done to maintain these machines. No lubrication to maintain The cleaner the filters are kept the better the machine will perform. The dirtier the filters the harder it is to pull air through them.

Remove muffler with 5/16" hex teck screws
The Rubber seal may be difficult to pull
apart, but it will separate after screws
are removed.

Fork lift hangers for top unit
Use these to lift off pallet and
to place on the bottom filter
unit after the bottom is set at
desired location.

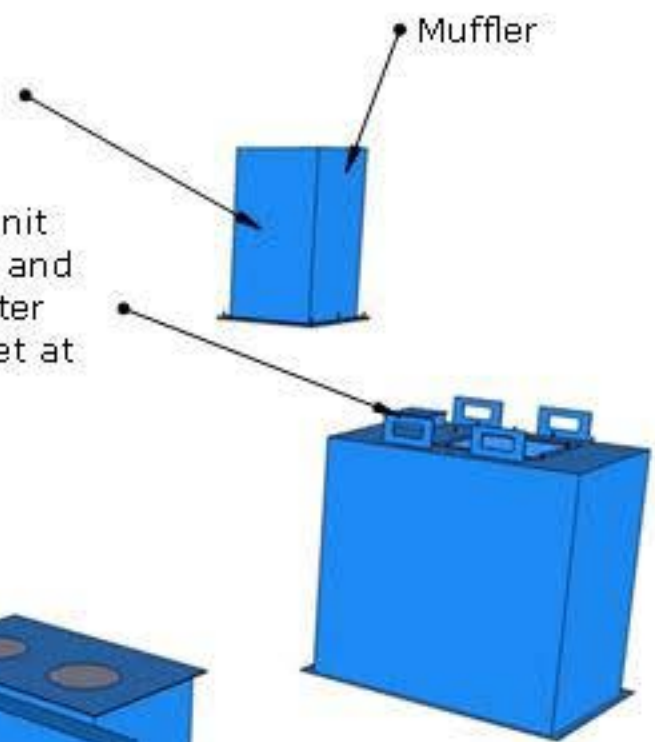

Fork lift pockets for bottom
also can move the complete machine
via these holes

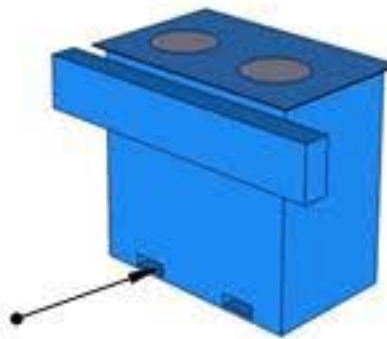

When setting the top unit onto the bottom
filter unit, the little side panels need to be removed
so you can see the two hoses to make sure
they clear the base of the top unit

When setting top onto the bottom
much attention should be used as
setting, so the holes align onto
each other properly. Use two large
round shafted screw drivers as shown
in the picture below. With 2 people
one on each side with screw drivers
inserted into holes as shown as the top
unit is placed onto the bottom unit
using screw drivers to maneuver the
top unit so holes properly align.
As being let down by fork lift
PLACE ALL BOLTS into the holes before
any are tightened.

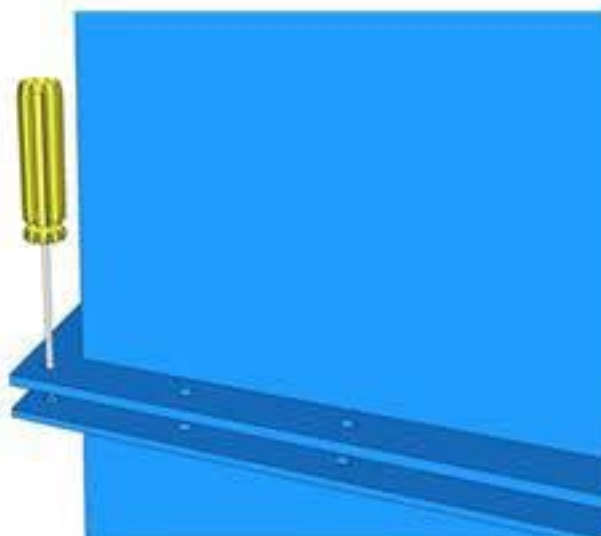
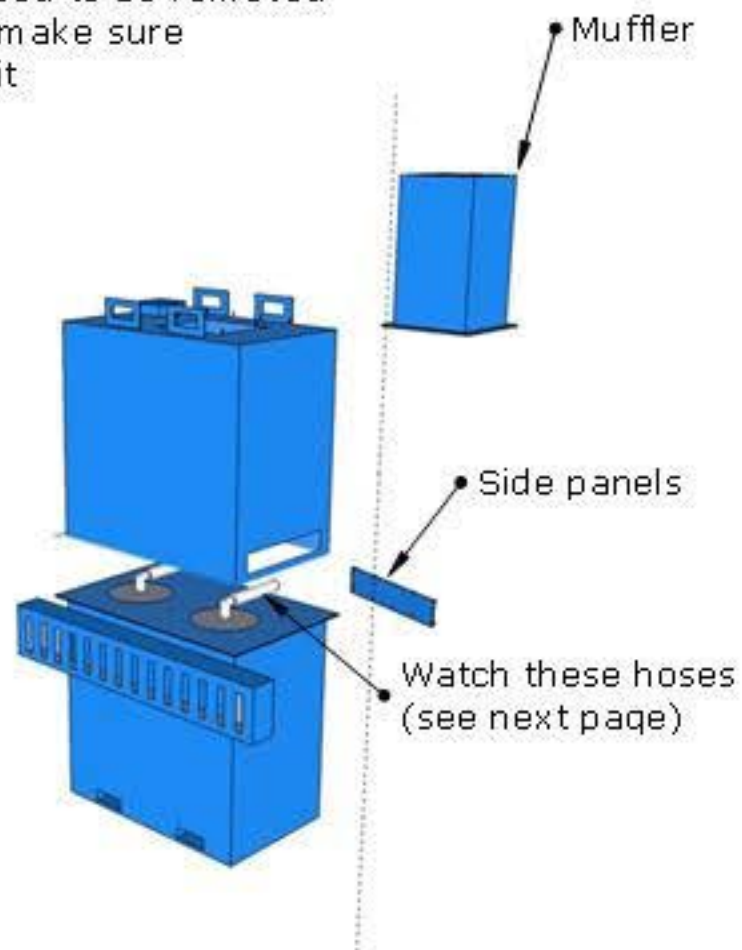

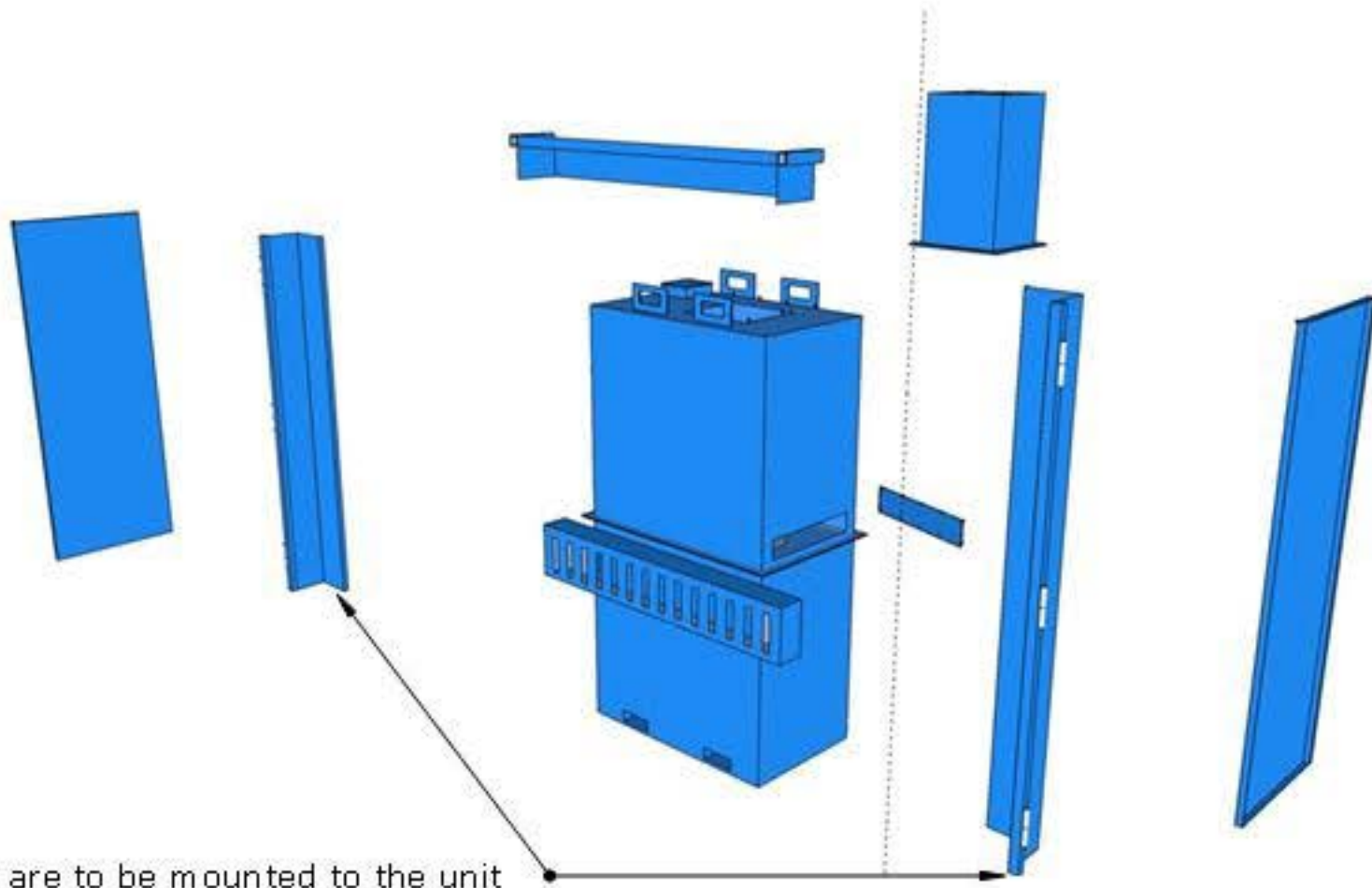

The two sides are to be mounted to the unit

Muffler to be mounted and screwed on
Now the top bracket

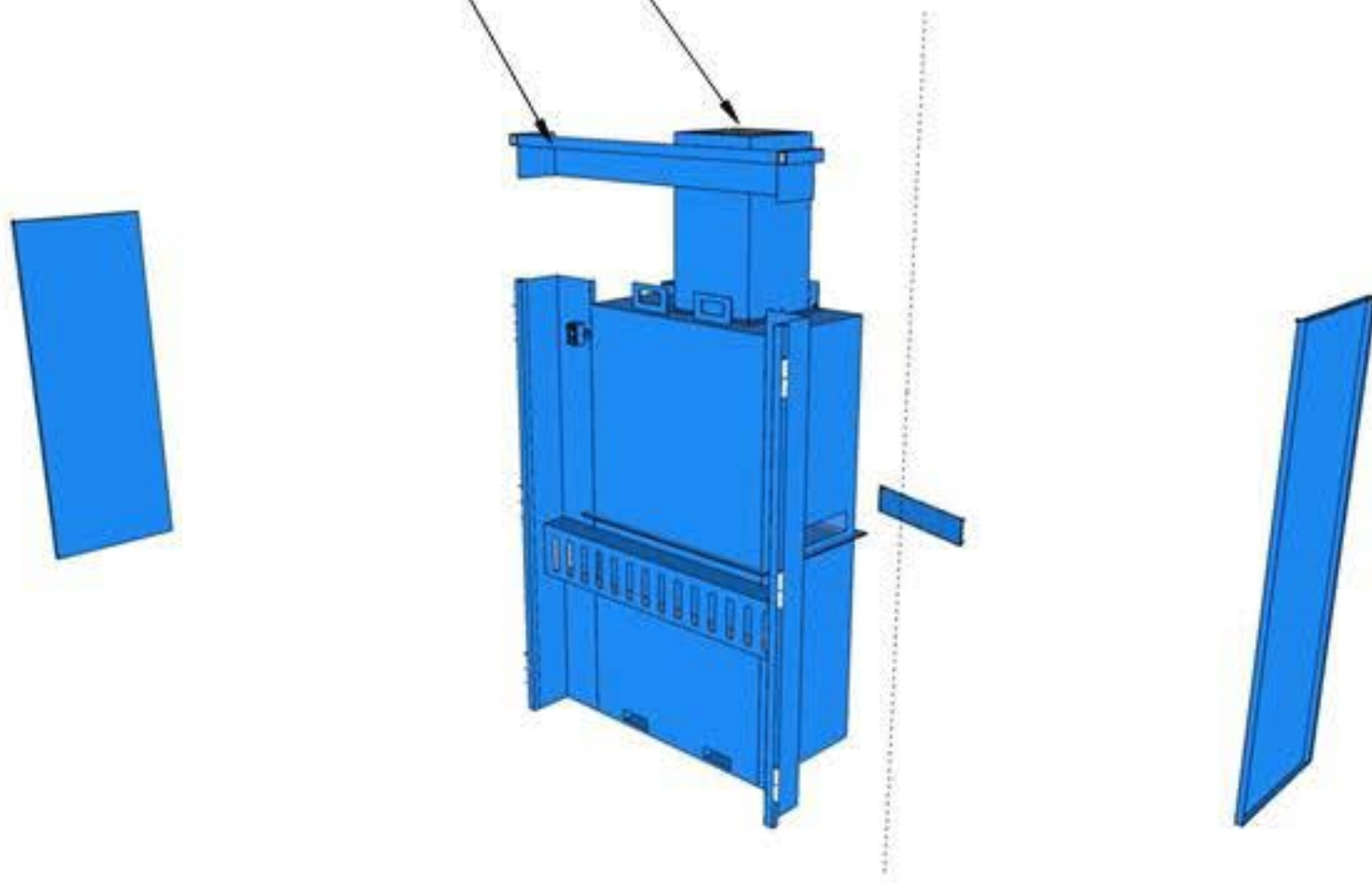



On each end /side there is a small panel held on with the 5/16" hex headed screws that opens to the hoses that leads to the air tank, remove the panel and you will see the hose that fits on the hosebib. placing the hose over the bib and tightening the hose clamp to secure the hose, so the filters can be pulsed cleaned.

hose not on

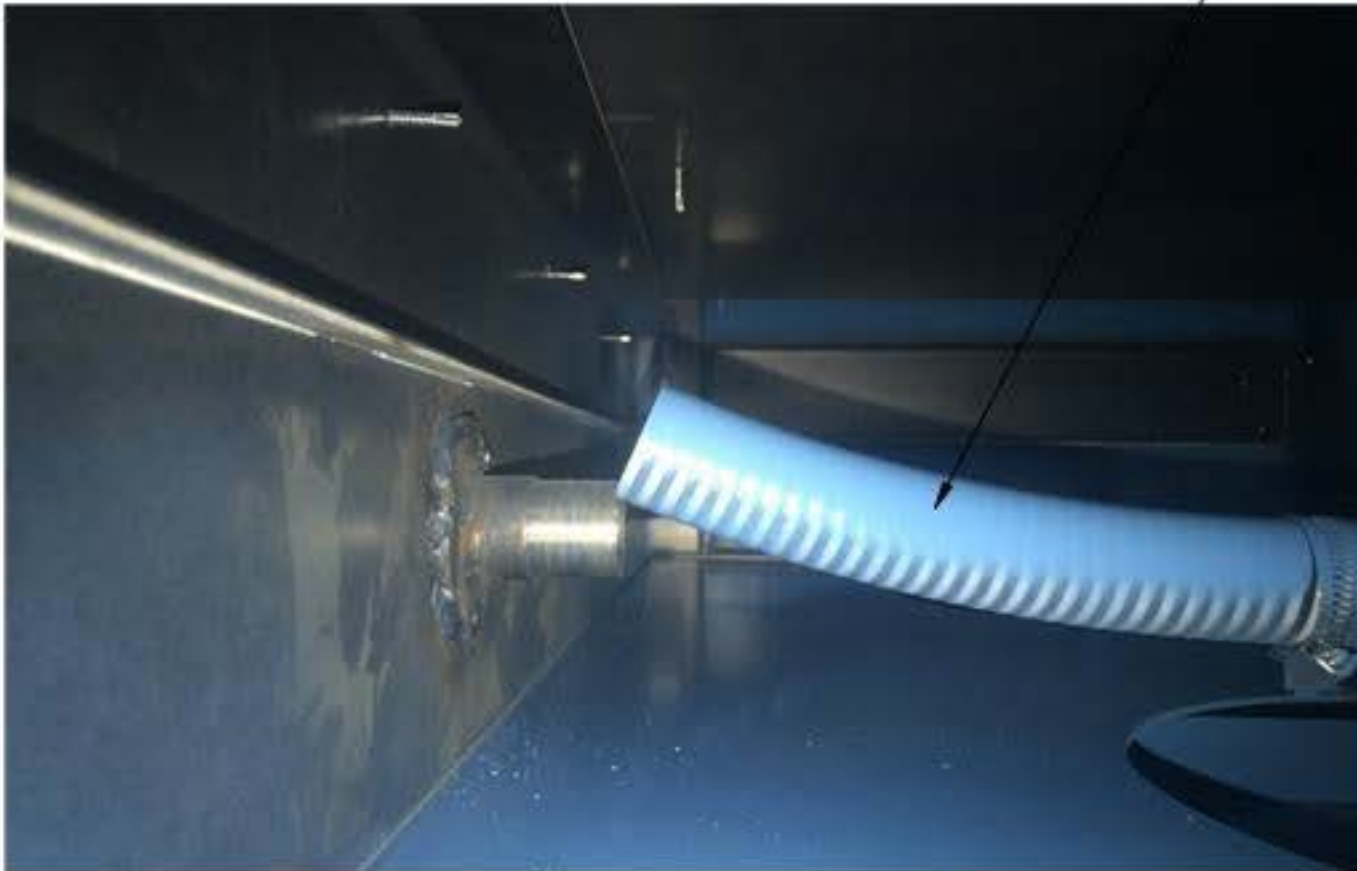

Hose placed over the bib and the clamp in place.



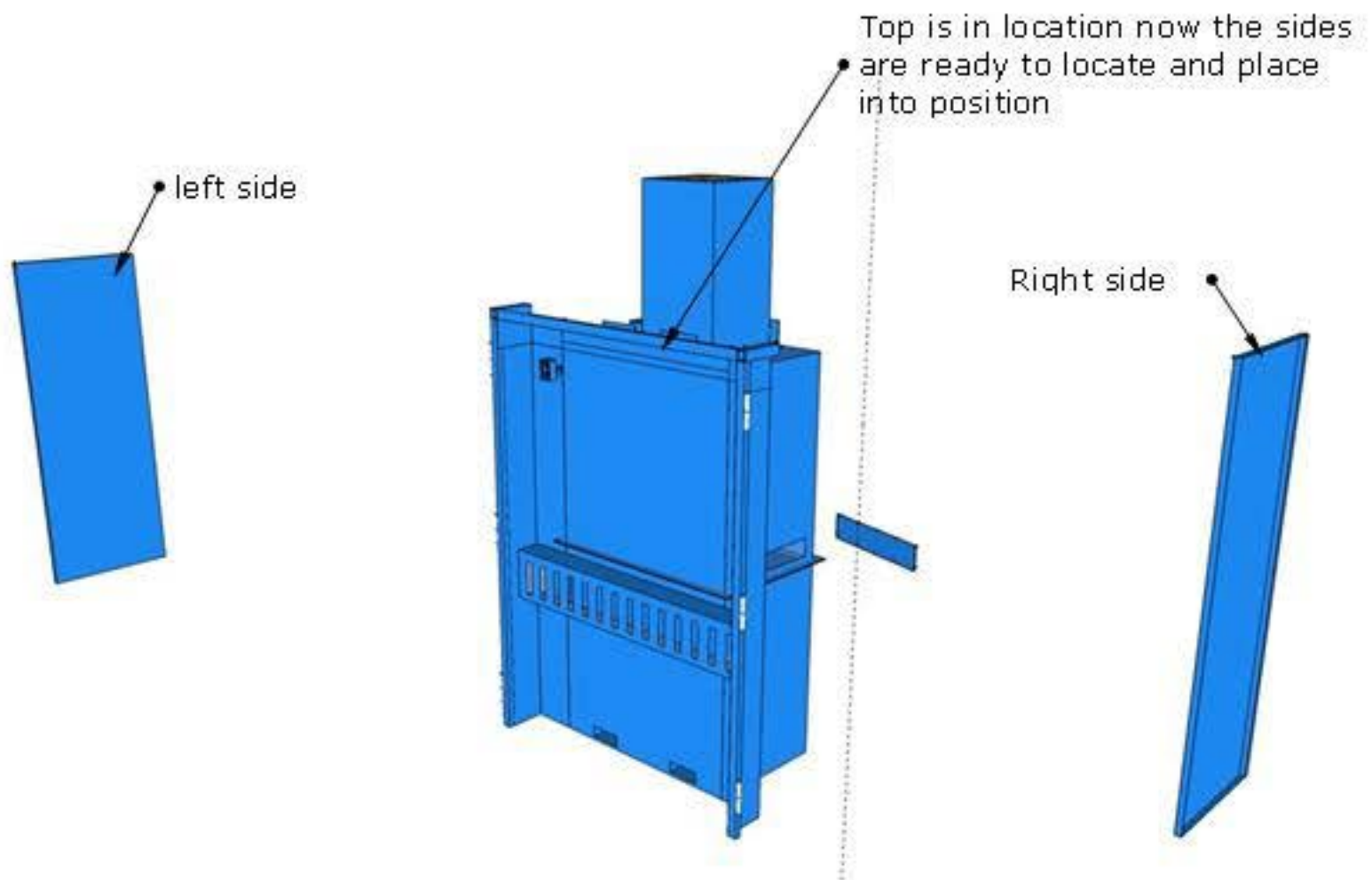

Weld on hinge is what secures the sides, just slide the pin into the hole. Lubrication like WD 40 will help allow the side to slide into hole better.

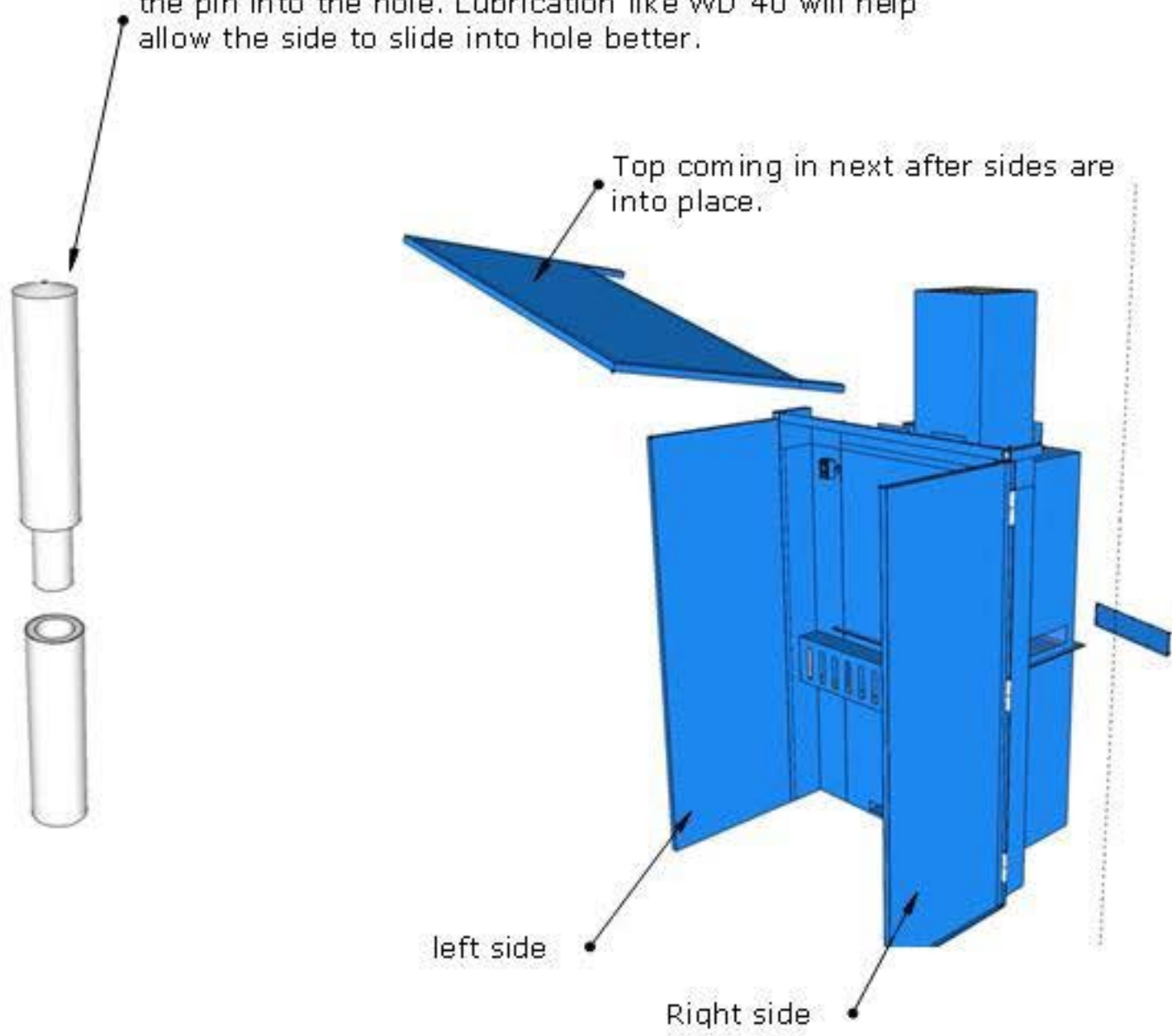

This is the top that mounts to the machine
This is the top that sits above the 3 ft swinging sides

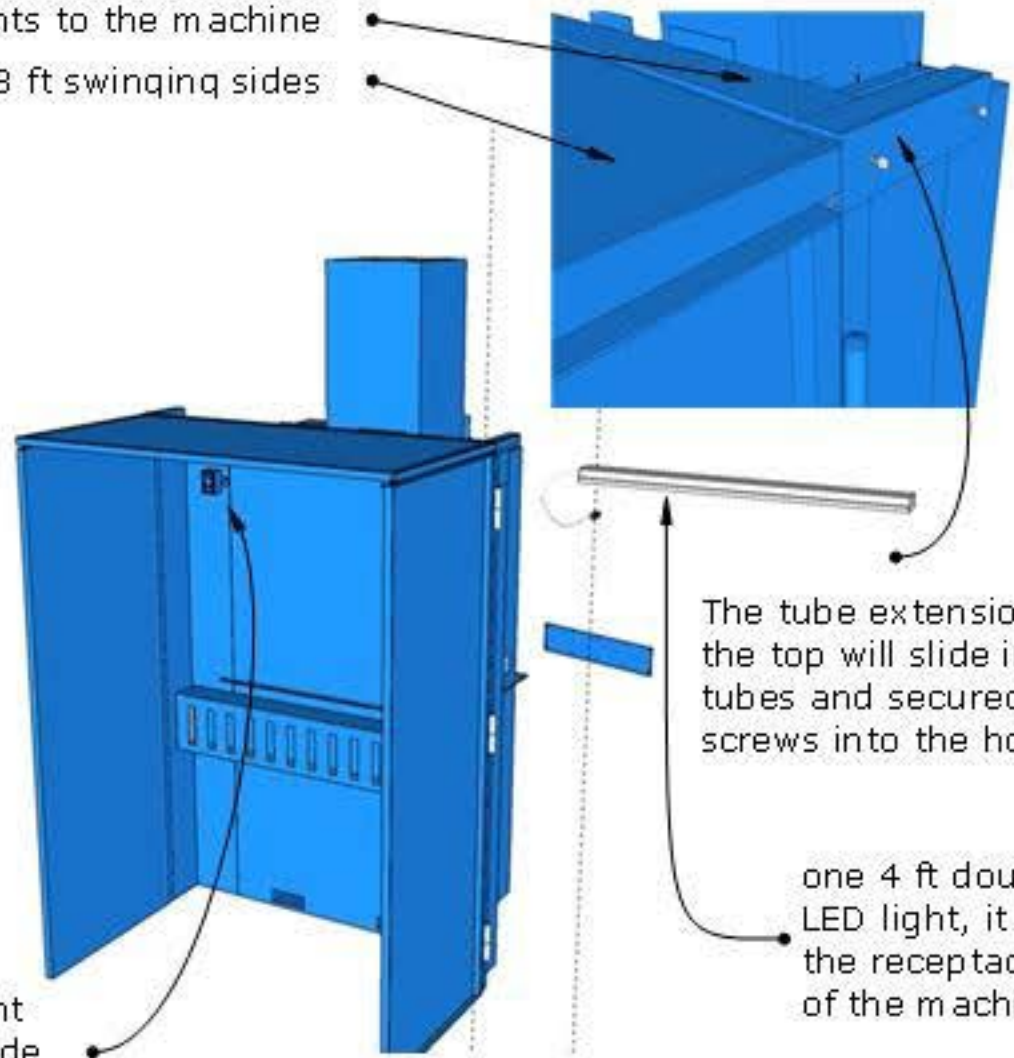

The tube extensions from the top will slide into these tubes and secured in with screws into the holes

one 4 ft double strip LED light, it plugs into the receptacle in front of the machine

Receptacle for the light the switch is on outside by the motor switch

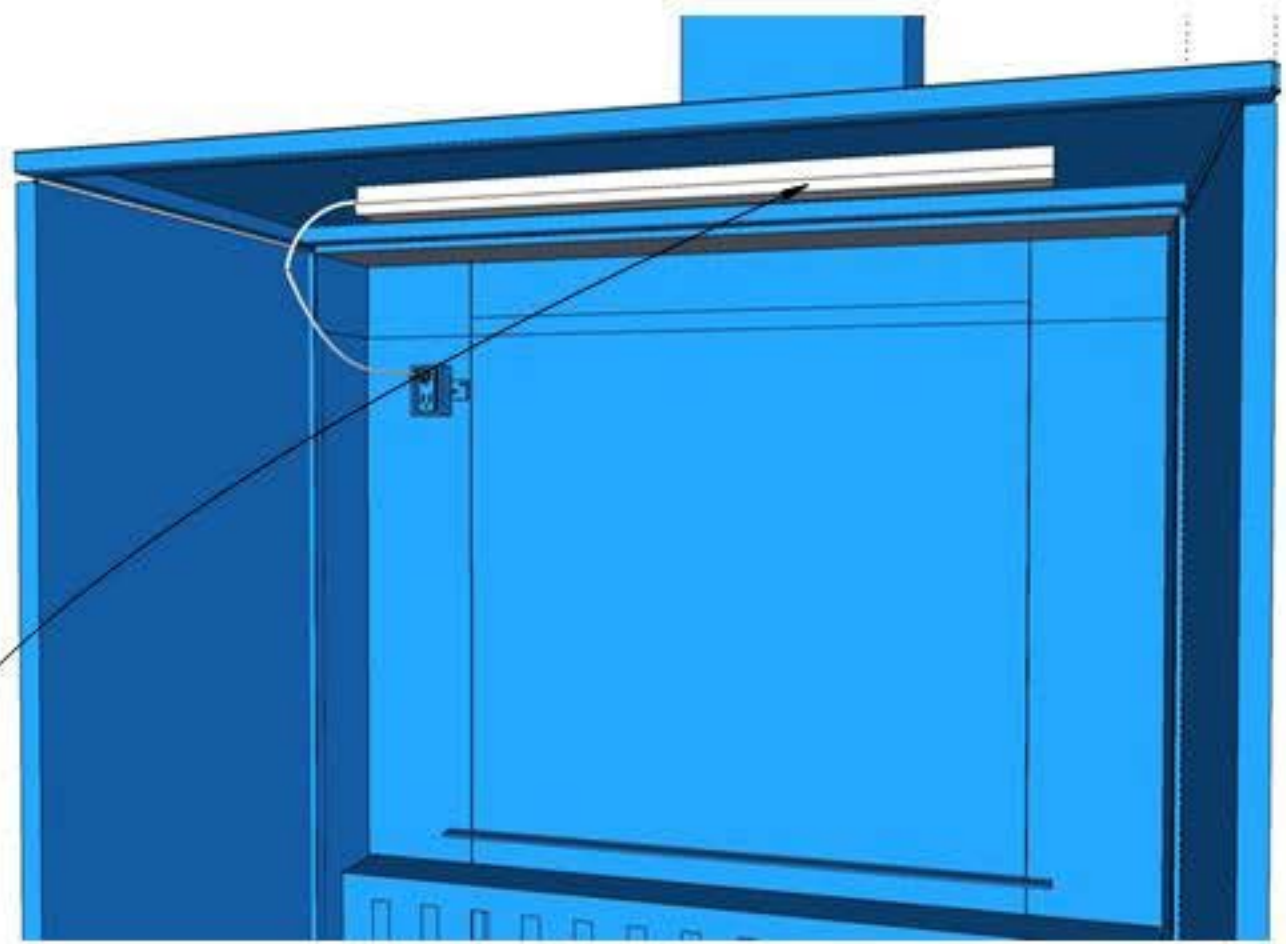

LED Light fixture

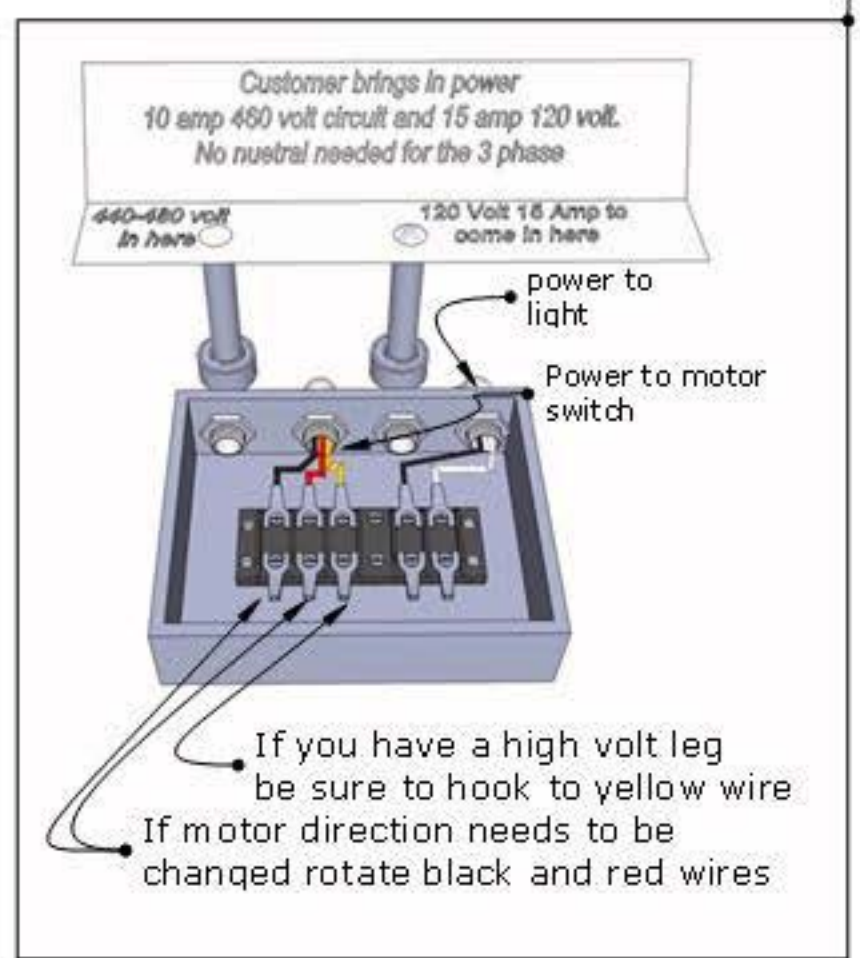
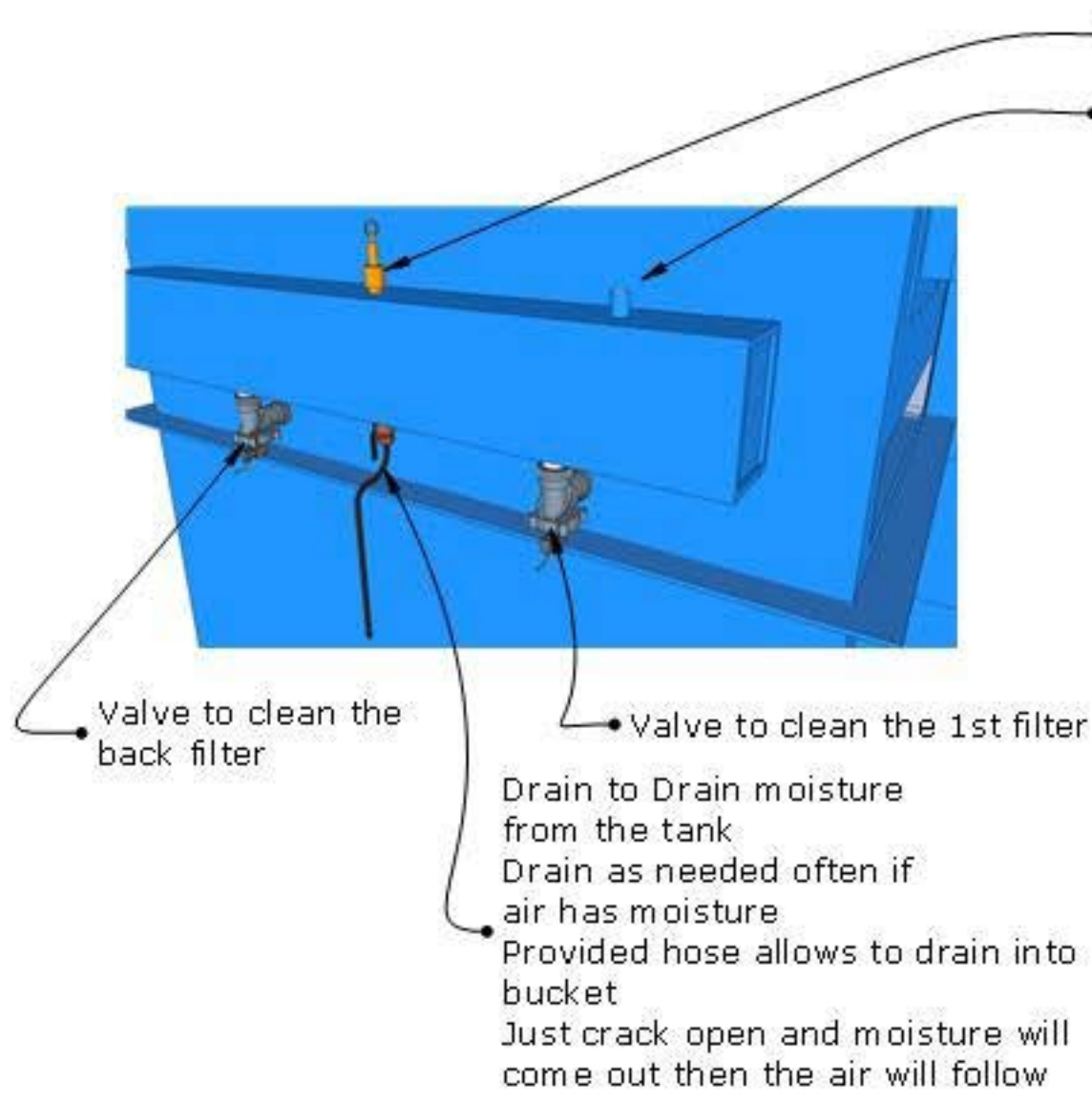
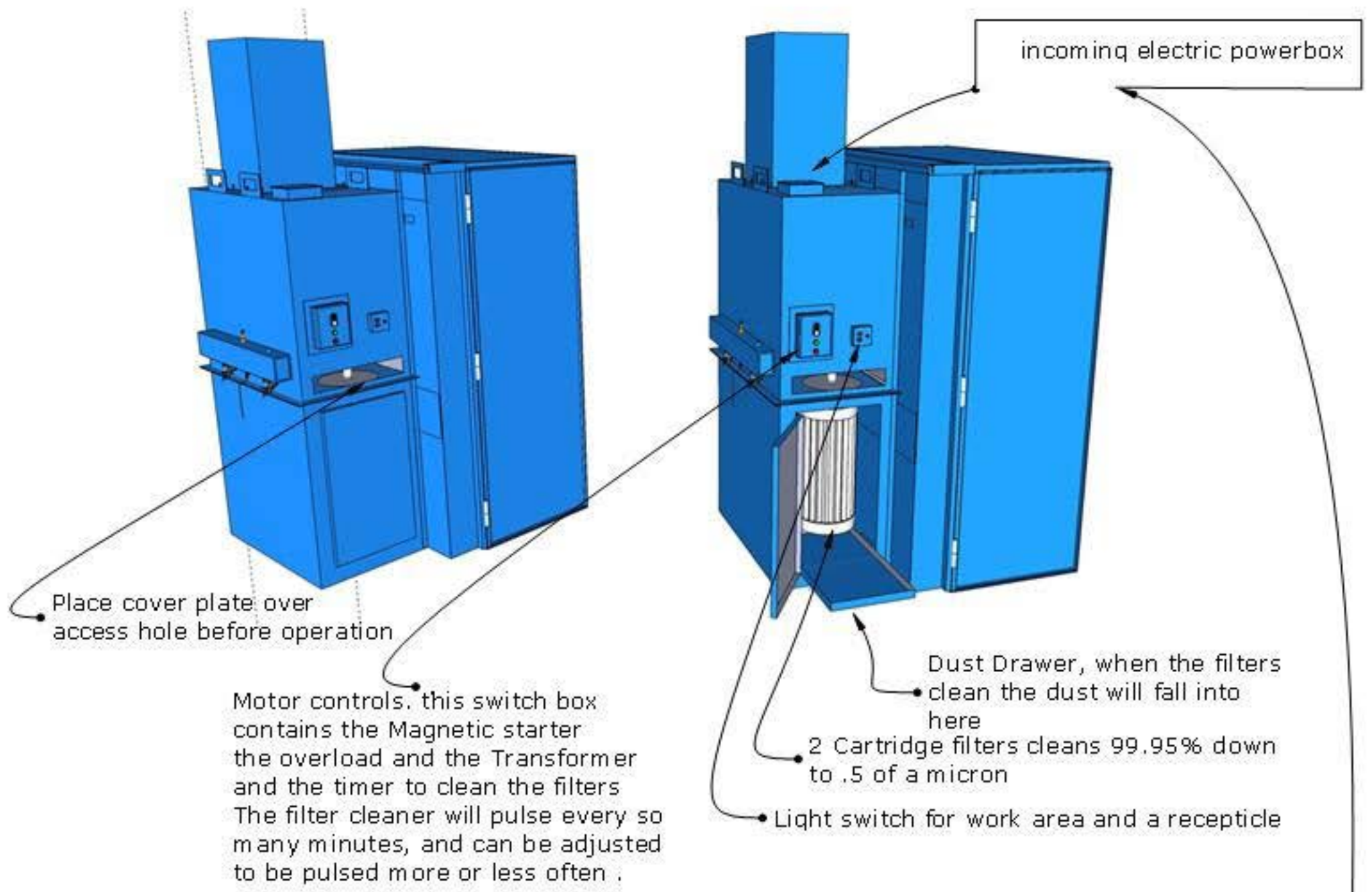

Positive Air VS Negative Air

Positive air is the air coming from compressed air gun, very forceful
Negative air comes from the fan in the filter unit,
FYI in the summer time and you are hot you stand on the
positive side of a blowing fan, BUT both sides are equal in air movement
it takes 10% of positive air to over power 100% negative air

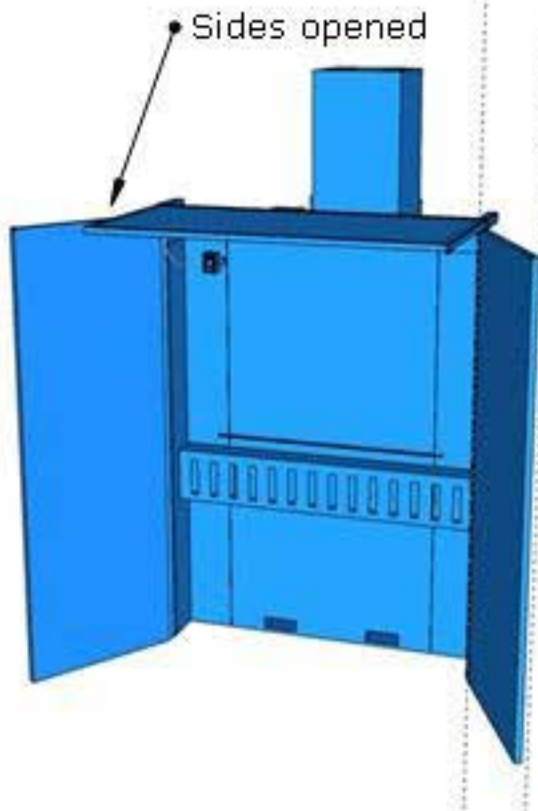

The sides are mounted to hinges so the sides can be swung out
Important.....If sides are swung out, the opening becomes wider,
which slows down air speed.

If higher air speed is needed a couple options we have , are to
reduce the opening of the front.

Below are a couple of ideas that may work in you setting.
Vinyl strips, that are easy to move through but will prevent
compressed air from blasting back out, from any blow
off gun.

With the vinyl strips on the top, the opening has been reduced
thus speeding up the air speed of the incoming air.

Bottom pictures shows the strips are on a fixed bar
8 inch strips that can be easily parted.

the pictures below the strips are on a roller track so the strips
can be separated for easy loading and unloading

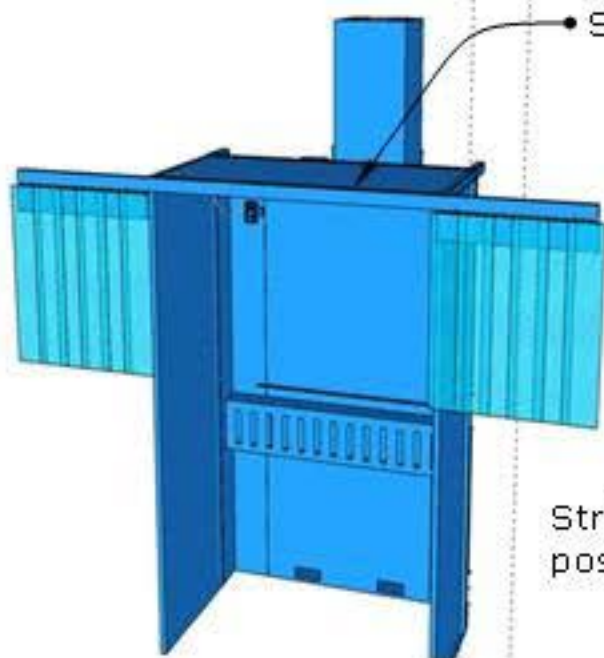

Strips on rollers in closed
position

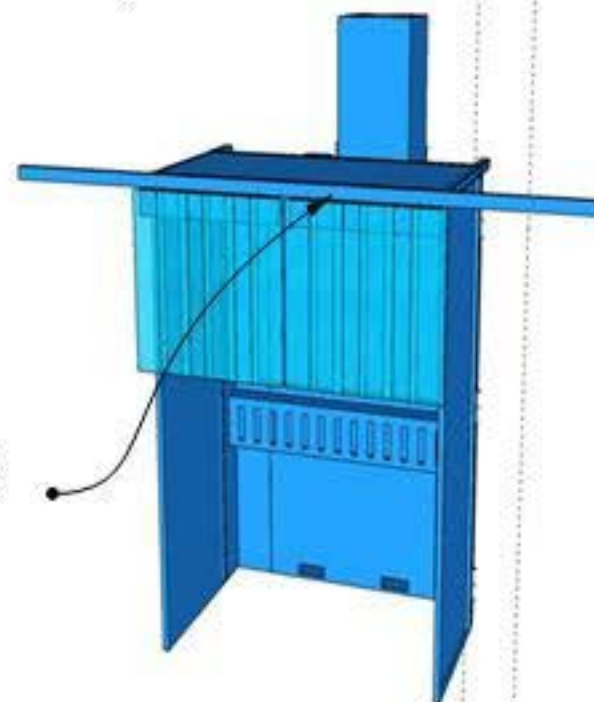

Fixed strips

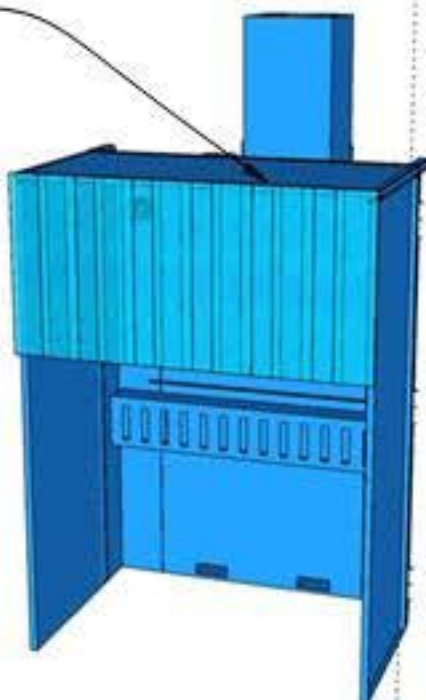

115/220 Volt 2 Timers

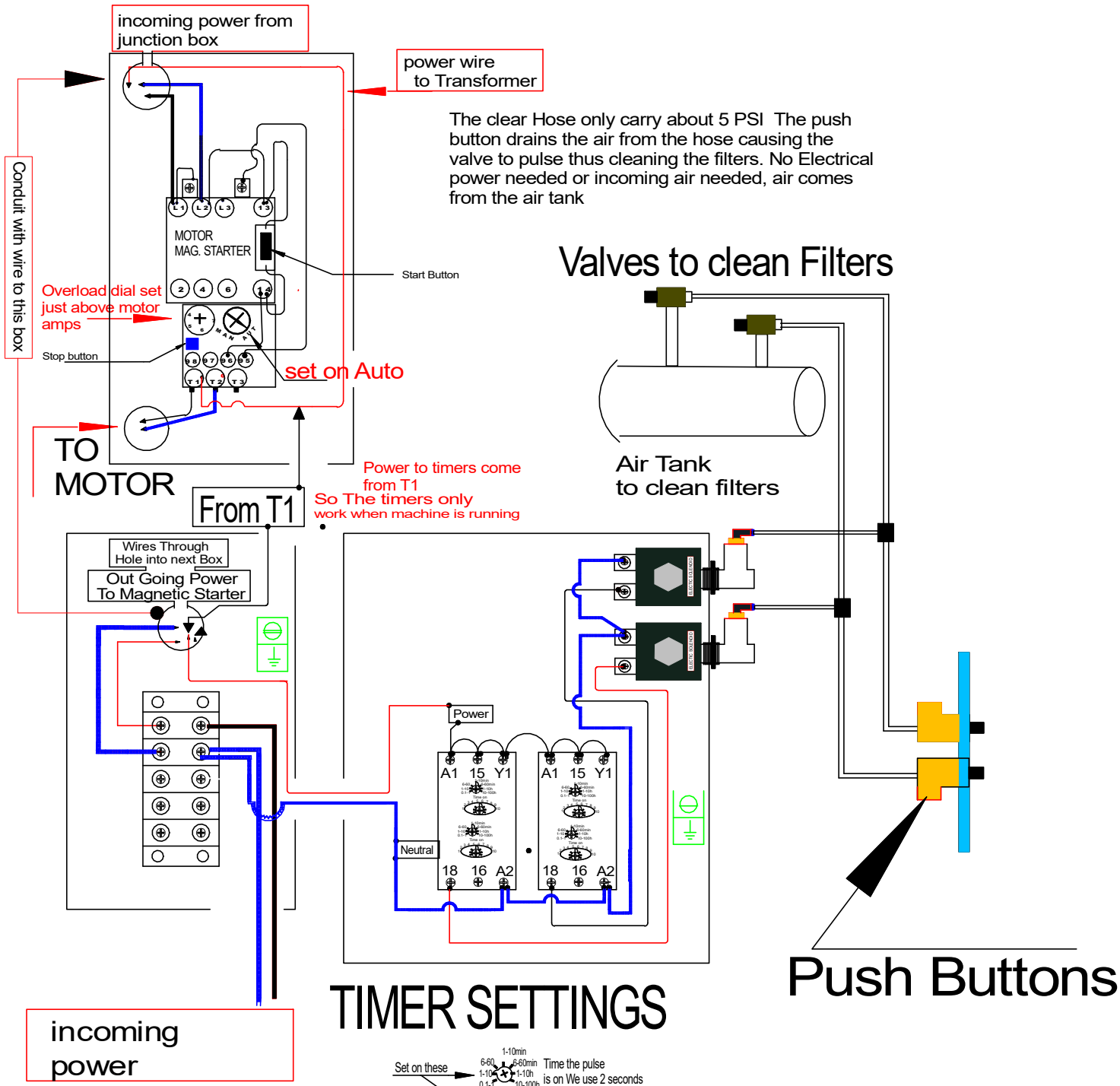

The clear Hose only carry about 5 PSI The push button drains the air from the hose causing the valve to pulse thus cleaning the filters. No Electrical power needed or incoming air needed, air comes from the air tank

Valves to clean Filters

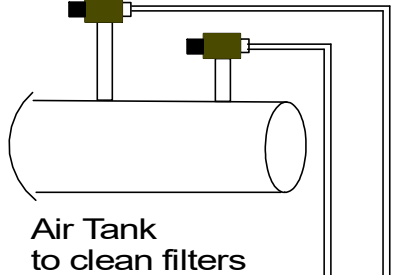

Air Tank to clean filters

TIMER SETTINGS

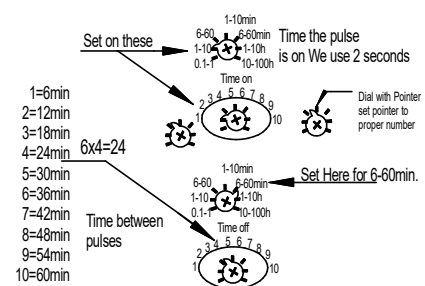

230 Volt 3 phase 2 Timers

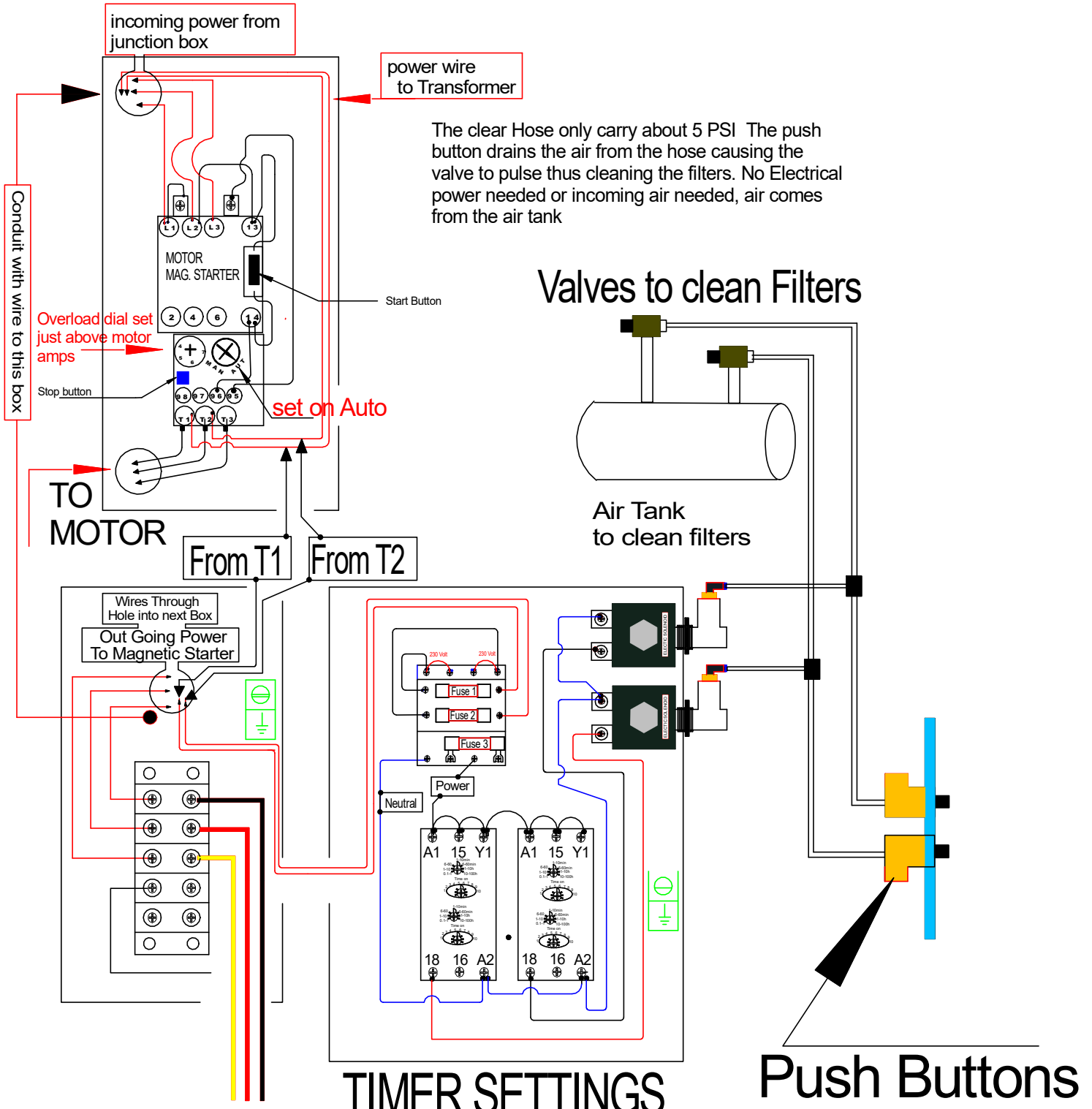

The clear Hose only carry about 5 PSI The push button drains the air from the hose causing the valve to pulse thus cleaning the filters. No Electrical power needed or incoming air needed, air comes from the air tank

TIMER SETTINGS

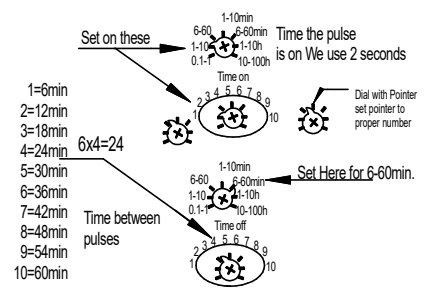

460 Volt 3 phase 2 Timers

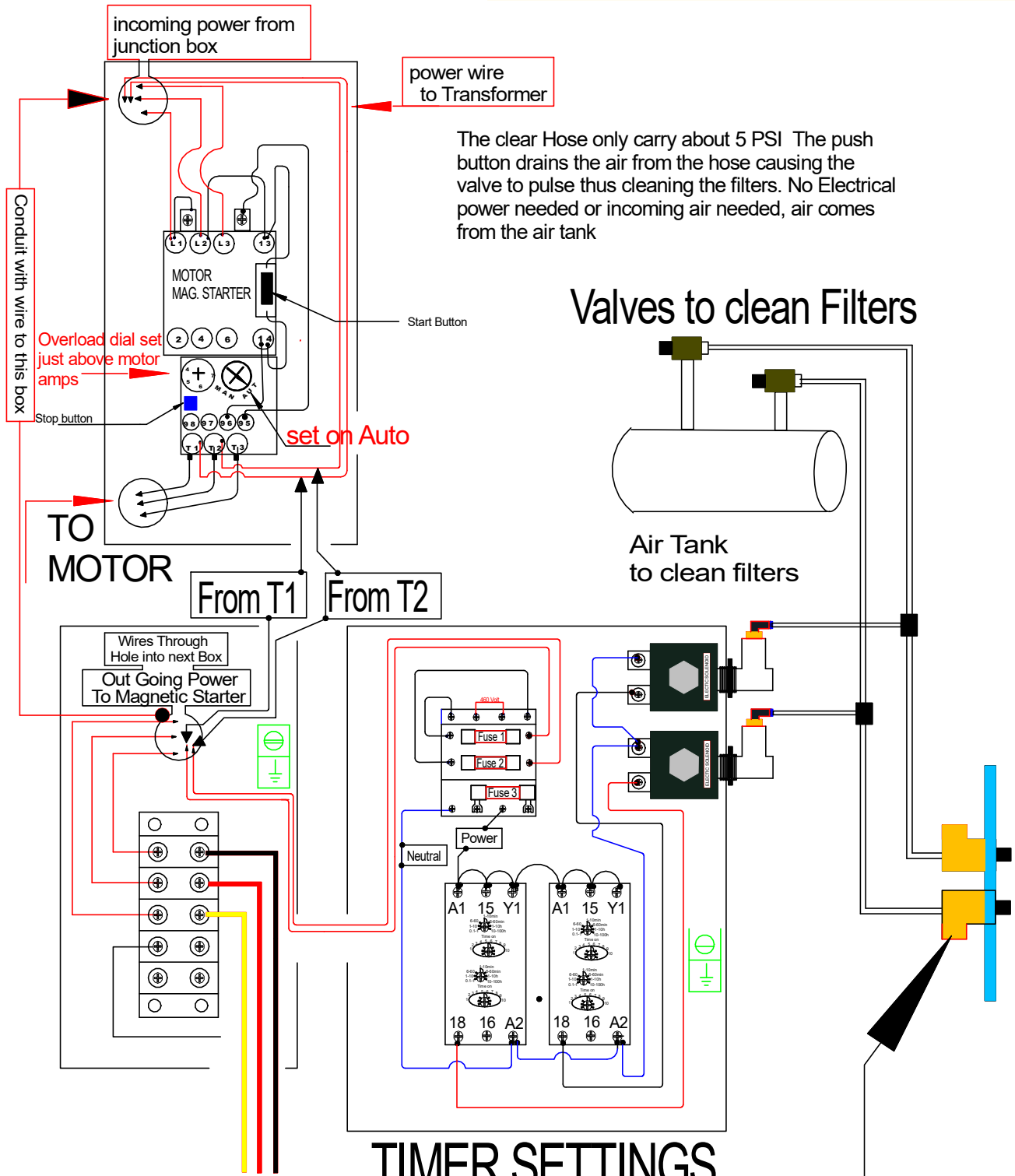

The clear Hose only carry about 5 PSI The push button drains the air from the hose causing the valve to pulse thus cleaning the filters. No Electrical power needed or incoming air needed, air comes from the air tank

TIMER SETTINGS

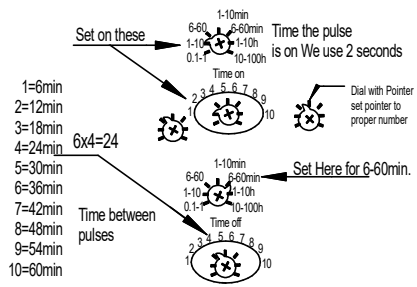

Push Button To Clean filter/s

TROUBLE SHOOTING

All the below solutions are meant to be done only by a qualified technician

1	Motor not running	Look to see if L1- L2 -L3 wires are in and secured and proper voltage is there	Check if wires at bottom of mag starter to the motor are in bottom and secured.
2	The above checks OK	In center of the contactor is a rectangle post that is hooked to coil below. With screwdriver push in and see if motor will run. If motor will run something is wrong with the push buttons, That activates the starter.	
3	Motor runs when center post is held in, but not by the switches	Make sure every wire is secured on starter if still no results call Denray for further assistance	
4	If center post is held in and nothing happens hook power leads to motor leads at bottom of mag starter if motor runs the problem is the starter.	Call factory for switch replacement	
5	If on switch closes mag starter and motor does not run.	FIRST take tester and check see if there is the proper voltage at bottom of starter	
6	If proper voltage is at bottom of starter	Check to see wiring at motor is properly hooked together	
7	Mag starter works and motor only hums	Check for proper voltage check all wire connections to be tight check wiring diagram and motor leads to be correct	
8	Motor runs for a few minutes and shuts off	Turn the amp dial on overload to increase the number. Increase only 1 amp at a time Never increase more than 2 amps above motor full load amps	
9	Filter Cleaning valve will not pulse	Check the three 1 amp fuses on top of the transformer in the switch box.	
10	Fuses OK	Check wiring in front of and behind the fuses	
11	Fuses and wiring checks out OK	With it being quiet activate the switch and listen to hear a clicking sound from the valve or valves.	
12	You hear it clicking	Make sure air is hooked up to tank	
13	Air is hooked up and it still clicks	Call Denray Replace valve	

TROUBLE SHOOTING

All the below solutions are meant to be done only by a qualified technician

14	Machines with timers Timer not working	Check fuses:: Check wiring between mag starter and timer. Any loose connection, secure the connection
15	Green light on timer does not work	See above Bad timer needs replacement
16	Filters need to be cleaned more often	Turn dial on timer to a lesser number set at factory at approx. every 20 minutes.
17	Lots of dirt remaining on filters after being cleaned	Decrease time between cleanings. Check air pressure going into machine. Keep between 100-140 psi
18	Filter never completely cleans all dirt off	Not supposed to:: Machine designed to operate at 30% filter blockage. The cleaner a filter is the better the machine will perform.
19	Loss of suction on top of table	Dirty filters :: Refer to above
20	Excessive exhaust air on the floor	Any air that is sucked into the table top must come out in exhaust somewhere. Look into adding Muffler to machine
21	Dirt packed in top 1/3 of filters	Rotate filters two times a week 1/4 turn
22	Inside of filters are rusty colored	Blowing water from air tank inside of filter. Drain air tank more often (daily if possible) Installation of a dryer or water trap may be necessary
23	Filters will not come clean	Pull filters out of machine and take blow gun and from inside blowing out give filters a deep cleaning
24	How often do I need to do the above	Some companies do it daily and some weekly and some monthly. You must determine that for yourself
25	Moisture blowed in filters will make filters harder to clean	Refer to 22
26	Are filters washable?	Spun-bond filters in the grind tables can be washed only a couple times and must let thoroughly dry. Filter cleaning service companies may be available in your area.

TROUBLE SHOOTING

All the below solutions are meant to be done only by a qualified technician

27	Fan making a loud roar	Fan rotation backwards, on three phase, switch wires on L1 and L2
28	Lack of proper suction	Fan running backwards will produce 2/3rds less suction check fan rotation Verify Correct Fan Direction on your Machine
29	Machine vibration on direct drive systems	All fans are factory balanced from fan company, fans checked and rebalanced at table MFG, if table has vibration, fan weights may need to be moved to another blade.